

ALUMINIUM ACIER

Coating

Number of flutes =

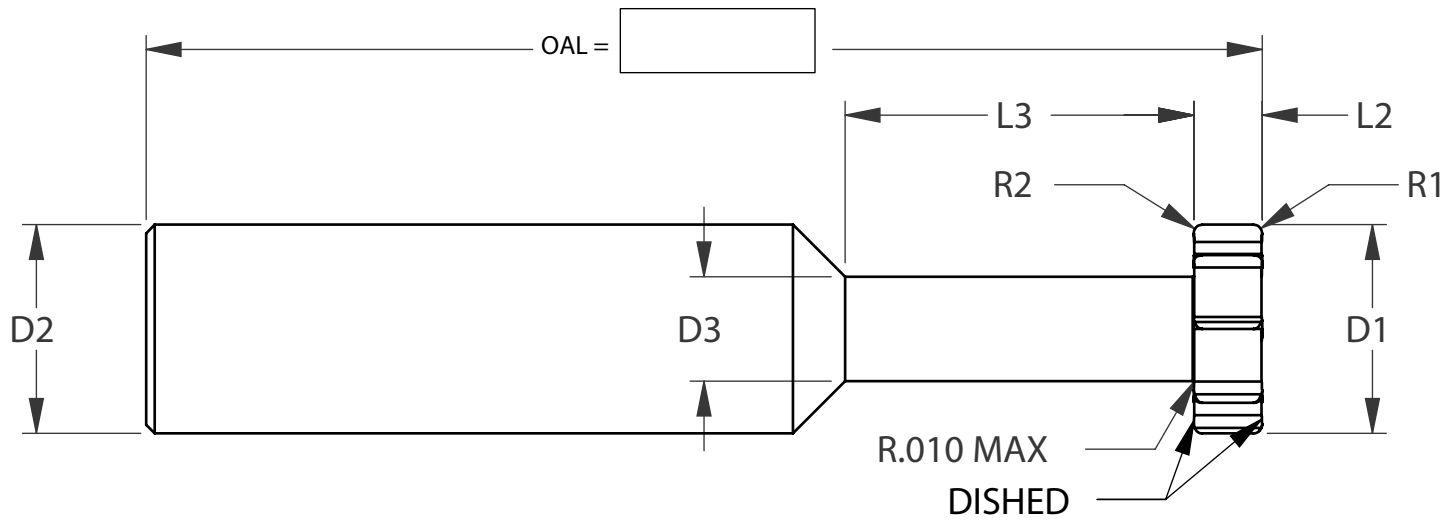

L2 =

L3 =

R1 =

R2 =

D1 =

D2 =

D3 =

Customer

Quantity =

Tolerance